



URBAN MARKET

COLLECTION

 DISPLAYS
Cayuga





Cayuga understands product merchandising today is about fresh presentation, versatility and innovation – often in smaller retail spaces. Retailer needs can be very specific, however budgets don't always allow for a fully custom case. This is where the Urban Market Collection comes in: customizable cases designed on a standard platform.

The Urban Market Collection reflects the latest styles and trends in the industry – helping you keep your look and brand fresh. Designed and manufactured at our own North American facility, the entire collection is fully customizable with a variety of finishes, colours, materials and other options.

And when you work with Cayuga Displays, you can always be confident we'll help you to select the right product and options, so that you have the food presentation that is certain to elevate your customers' experience and enhance your brand – beautifully.

“Longo's is pleased to support Cayuga Displays. Your team's quick service/turnaround for projects has helped us with our millwork for bakery and floral in past projects. More recently your team has come up with some cost effective refrigeration solutions for our bakery and produce.”

Paul Collette,
Longo's Support Center
Project Manager Real Estate
and Construction

THINGS TO CONSIDER

Showcases are designed to display your refrigerated products at 38-41°F (4-5°C). Showcases are designed to perform correctly when placed in environmental conditions of maximum 75°F (23°C) and 55% relative humidity.

When selecting a showcase and placing it in your store environment, you need to consider the following:

1 Consider nearby doorways

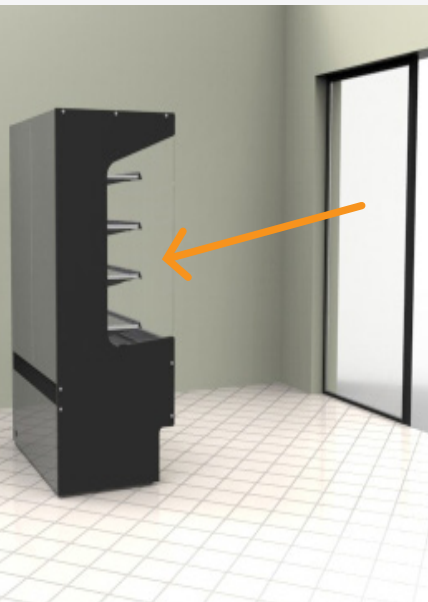

A location near a doorway will affect the airflow and holding temperature of open and closed showcases.

2 Consider nearby windows



Direct sunlight will affect the holding temperature of open or closed showcases.

3 Consider nearby vent sources and fans



HVAC ceiling vents and ceiling fans will affect the airflow of open showcases and could create condensation on the glass of closed showcases.

4 Ensure your display is level and plumb



Ensure your showcase is plumb and level to allow for proper drainage of condensation water.

Maintenance

Your showcase will work at its peak performance with regular maintenance. An owners' manual with maintenance instructions is included or you can also check out our online maintenance video.



Watch our maintenance video at cayugadisplays.com/maintenance

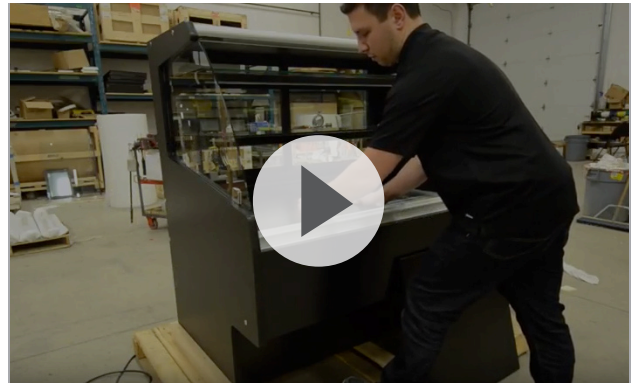

5 Leave appropriate space behind displays

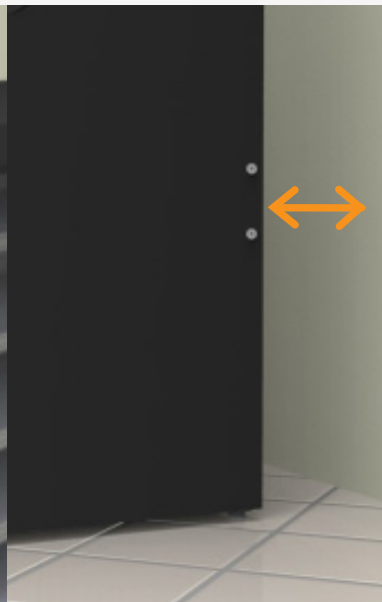

A 6" space is required behind any showcase that is against a wall or has a rear obstruction.

6 Clean your display



Use the included brush to regularly wipe away dust. Too much dust will not allow the refrigeration to work properly and could result in damage.

7 No Warm Product in Case



Refrigerated displays are designed to **KEEP COLD PRODUCT COLD** - they are not designed to bring warm product down to a cold temperature. For food safety it is always imperative that warm product be properly chilled (using a blast chiller or cold room) prior to storing in the refrigerated display case.

8 Noise



Self-contained cases have compressor motors and fans and these will make noise, just as your household refrigerator makes noise. Keeping your showcase serviced and clean will help keep the noise level under control.

CURVED GLASS COMBINATION SERVICE/ SELF-SERVICE DISPLAY

 REFRIGERATED

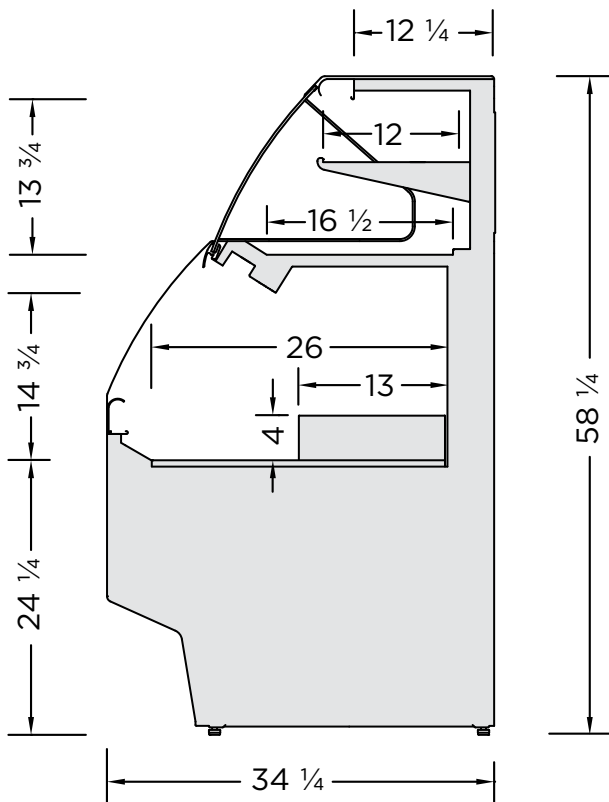

MODEL	LENGTH
SSS-38	40 1/4"
SSS-48	49 7/8"
SSS-57	59 3/8"
SSS-76	78 1/2"

FEATURES:

- 3 interior finishes, textured black, white or brushed stainless steel
- Many exterior colors, patterns and wood grain finishes available
- R-134A self-contained refrigeration
- Sliding baffle between the service/self-service areas to create a dry service display
- 12" adjustable tempered glass shelf in the top service display area
- Tilt-out front glass on the top display area for easy cleaning
- Removable 4" riser step in the self-service display area (shelf options available)
- Removable base deck panels for easy cleaning and service
- LED lighting attached to the top ledge of the service and the self-service display
- Thermal rear sliding doors on the service display
- Many custom options available. Refer to the options schedule on next page

SUGGESTED APPLICATIONS:

-  Bakery
-  Restaurants
-  Deli
-  Cafe

Note: Information and specifications may change due to engineering improvements.



CURVED GLASS COMBINATION SERVICE/ SELF-SERVICE DISPLAY

 REFRIGERATED

ELECTRICAL SPECIFICATIONS			
MODEL	VOLTS	AMPS	NEMA PLUG
SSS-38	115	11.6	5-15P
SSS-48	115	11.9	5-15P
SSS-57	115/230	8.8	L14-20P
SSS-76	115/230	9.8	L14-20P

STANDARD OPTIONS:

- Textured black, white or brushed stainless steel interior finish
- Black or white laminate exterior finish
- 12" tempered glass shelf in the service display
- Removable 4"H riser step in the self-service display area
- LED lighting attached at the top of the service and the self-service display
- Thermal glass rear sliding doors on the service display
- Tilt-out curved front glass on the service display
- Sliding baffle for top ambient service display

CUSTOM OPTIONS:

EXTERIOR FINISHES	
Formica laminate finish: ____	
Other laminate finish (specify): ____	
Customer laminate choices	
Oak Veneer Plywood	
- Vertical grain direction	
- Horizontal grain direction	
Birch/Maple Veneer Plywood	
- Vertical grain direction	
- Horizontal grain direction	
Clear Finish applied to veneer	
Stain Finish Choice _____	
1" black McCue impact bumper strip applied to the front of the display	
Other McCue impact bumper strip colors Available upon request	

END PANELS	
Interior laminate the same as exterior	
Mirrored interior	
Brushed Stainless Steel interior	
Mirrored end panel glass	
Stainless Steel T-mold edging	
1" black McCue impact bumper strip applied to the outside of the end panel	
Other McCue impact bumper strip colors available upon request	

MISCELLANEOUS	
Rear loading doors for the self-service display area	
Heavy duty lockable casters	
Add 1 shelf level to the bottom self-service display area (instead of riser step inlay)	
Mirrored rear sliding doors	
Locks for rear sliding doors	
Wire security grill panel for service display area	
Price tag molding strip for tempered glass shelves	

ADDITIONAL FEATURES:

- Designed to maintain product temperature of 38-41°F with a maximum ambient atmosphere of 75°F/55% humidity
- Hot gas condensate evaporation system
- ETL Listed and Sanitation certified to NSF 7
- 1 Year Parts & Labour Warranty
- Rear air intake, front discharge. Avoid any obstructions in these areas

SLIM-LINE CURVED GLASS COMBINATION SERVICE/Self-SERVICE DISPLAY

 REFRIGERATED

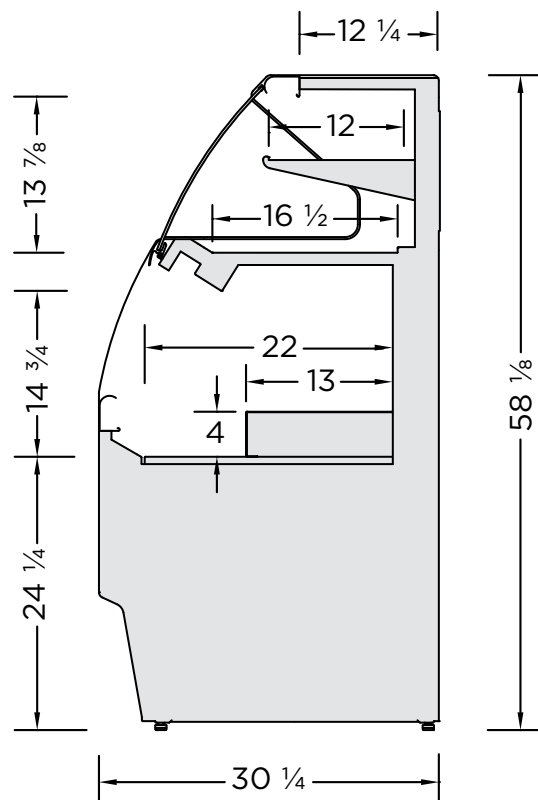

MODEL	LENGTH
SLS-38	40 1/4"
SLS-48	49 7/8"
SLS-57	59 3/8"
SLS-76	78 1/2"

FEATURES:

- 3 interior finishes, textured black, white or brushed stainless steel
- Many exterior colors, patterns and wood grain finishes available
- R-134A self-contained refrigeration
- Sliding baffle between the service/self-service areas to create a dry service display
- 12" adjustable tempered glass shelf in the top service display area
- Tilt-out front glass on the top display area for easy cleaning
- Removable 4" riser step in the self-service display area (shelf options available)
- Removable base deck panels for easy cleaning and service
- LED lighting attached to the top ledge of the service and the self-service display
- Thermal rear sliding doors on the service display
- Many custom options available. Refer to the options schedule on next page

SUGGESTED APPLICATIONS:

-  Bakery
-  Restaurants
-  Deli
-  Cafe

Note: Information and specifications may change due to engineering improvements.



SLIM-LINE CURVED GLASS COMBINATION SERVICE/ SELF-SERVICE DISPLAY

 REFRIGERATED

ELECTRICAL SPECIFICATIONS			
MODEL	VOLTS	AMPS	NEMA PLUG
SLS-38	115	11.6	5-15P
SLS-48	115	11.9	5-15P
SLS-57	115/230	8.8	L14-20P
SLS-76	115/230	9.5	L14-20P

STANDARD OPTIONS:

- Textured black, white or brushed stainless steel interior finish
- Black or white laminate exterior finish
- 12" tempered glass shelf in the service display
- Removable 4"H riser step in the self-service display area
- LED lighting attached at the top of the service and the self-service display
- Thermal glass rear sliding doors on the service display
- Tilt-out curved front glass on the service display
- Sliding baffle for top ambient service display

CUSTOM OPTIONS:

EXTERIOR FINISHES	
Formica laminate finish: ____	
Other laminate finish (specify): ____	
Customer laminate choices	
Oak Veneer Plywood	
- Vertical grain direction	
- Horizontal grain direction	
Birch/Maple Veneer Plywood	
- Vertical grain direction	
- Horizontal grain direction	
Clear Finish applied to Veneer	
Stain Finish Choice _____	
1" black McCue impact bumper strip applied to the front of the display	
Other McCue impact bumper strip colors Available upon request	

END PANELS	
Interior laminate the same as exterior	
Mirrored interior	
Brushed Stainless Steel interior	
Mirrored end panel glass	
Stainless Steel T-mold edging	
1" black McCue impact bumper strip applied to the outside of the end panel	
Other McCue impact bumper strip colors available upon request	

MISCELLANEOUS	
Heavy duty lockable casters	
Rear loading doors for the self-service display area	
Price tag mold strip for tempered glass shelves	
Mirrored rear sliding doors	
Locks for rear sliding doors	
Wire security grill panel for service display area	
Add 1 shelf level to the bottom self-service display area (instead of riser step inlay)	

ADDITIONAL FEATURES:

- Designed to maintain product temperature of 38-41°F with a maximum ambient atmosphere of 75°F/55% humidity
- Hot gas condensate evaporation system
- ETL Listed and Sanitation certified to NSF 7
- 1 Year Parts & Labour Warranty
- Rear air intake, front discharge. Avoid any obstructions in these areas

SQUARE GLASS COMBINATION SERVICE/ SELF-SERVICE DISPLAY

 REFRIGERATED

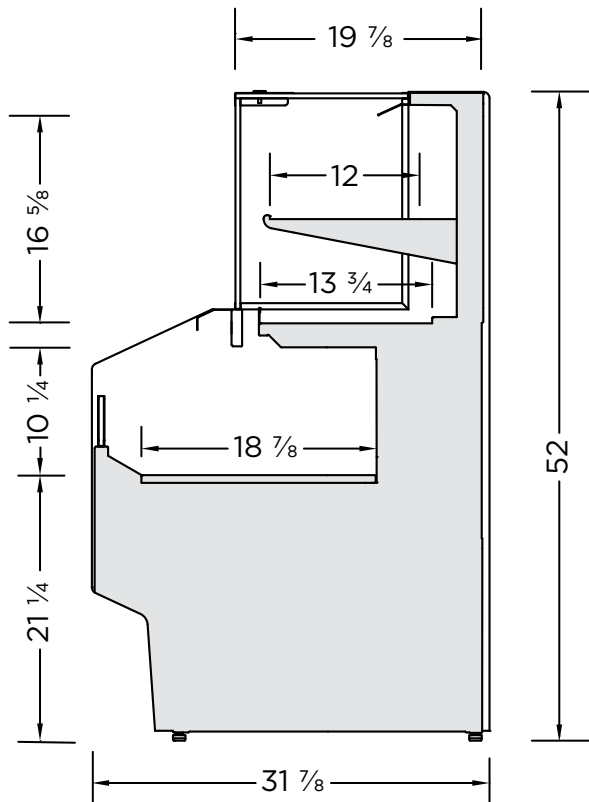

MODEL	LENGTH
ST-SSS-38-52	40 1/4"
ST-SSS-48-52	49 7/8"

FEATURES:

- 3 interior finishes, textured black, white or brushed stainless steel
- Many exterior colors, patterns and wood grain finishes available
- R-134A self-contained refrigeration
- Sliding baffle between the service/self-service areas to create a dry service display
- 12" adjustable tempered glass shelf with integrated LED lighting in the top service display area
- Unique all square glass top display area
- Removable base deck panels for easy cleaning and service
- LED lighting attached to the top ledge of the service and self-service display
- Thermal rear sliding doors on top service display
- Many custom options available. Refer to the options schedule on next page

SUGGESTED APPLICATIONS:

-  Bakery
-  Cafe

Note: Information and specifications may change due to engineering improvements.



SQUARE GLASS COMBINATION SERVICE/SELF-SERVICE DISPLAY

 REFRIGERATED

ELECTRICAL SPECIFICATIONS			
MODEL	VOLTS	AMPS	NEMA PLUG
ST-SSS-38-52	115	11.6	5-15P
ST-SSS-48-52	115	11.9	5-15P

STANDARD OPTIONS:

- Textured black, white or brushed stainless steel interior finish
- Black or white laminate exterior finish
- 12" tempered glass shelf in the service display
- LED lighting attached at the top of the service and the self-service display areas
- Thermal glass rear sliding doors on the service display
- Sliding baffle for top ambient service display

CUSTOM OPTIONS:

EXTERIOR FINISHES	
Formica laminate finish: ____	
Other laminate finish (specify): ____	
Customer laminate choices	
Oak Veneer Plywood	
- Vertical grain direction	
- Horizontal grain direction	
Birch/Maple Veneer Plywood	
- Vertical grain direction	
- Horizontal grain direction	
Clear Finish applied to veneer	
Stain Finish Choice _____	
1" black McCue impact bumper strip applied to the front of the display	
Other McCue impact bumper strip colors Available upon request	

END PANELS	
Solid	
- LH (visualized from the front)	
- RH (visualized from the front)	
Stainless Steel T-mold edging	
1" black McCue impact bumper strip applied to the outside of the end panel	
Other McCue impact bumper strip colors available upon request	

MISCELLANEOUS	
Rear loading doors for the self-service display area	
Price tag mold strip for tempered glass shelves	
Eliminate 1 shelf level	
Mirrored rear sliding doors	
Locks for rear sliding doors	
Heavy duty lockable casters	
Locks for rear sliding doors	

ADDITIONAL FEATURES:

- Designed to maintain product temperature of 38-41°F with a maximum ambient atmosphere of 75°F/55% Humidity
- Hot gas condensate evaporation system
- ETL Listed and Sanitation certified to NSF 7
- 1 Year Parts & Labour Warranty
- Rear air intake, front discharge. Avoid any obstructions in these areas.

SQUARE GLASS COMBINATION SERVICE/ SELF-SERVICE DISPLAY

 REFRIGERATED







MODEL	LENGTH
SG-SSS-38	40 1/4"
SG-SSS-48	49 7/8"
SG-SSS-57	59 3/8"
SG-SSS-76	78 1/2"

FEATURES:

- 3 interior finishes, textured black, white or brushed stainless steel
- Many exterior colors, patterns and wood grain finishes available
- R-134a self contained refrigeration
- Two 16" adjustable tempered glass shelves with integrated LED lighting
- Opening in the front glass to provide a self-service base display
- Removable base deck panels for easy cleaning and service
- LED lighting attached to the top ledge of the display
- Thermal rear sliding doors
- Many custom options available. Refer to the options schedule on next page

SUGGESTED APPLICATIONS:

-  Bakery
-  Restaurants
-  Deli
-  Butcher shops
-  Cafe

Note: Information and specifications may change due to engineering improvements.

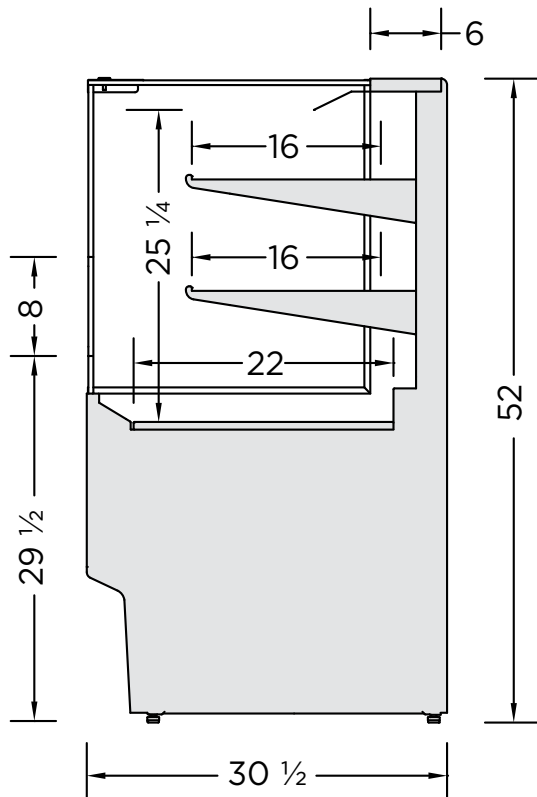



SQUARE GLASS COMBINATION SERVICE/SELF-SERVICE DISPLAY

 REFRIGERATED

ELECTRICAL SPECIFICATIONS			
MODEL	VOLTS	AMPS	NEMA PLUG
SG-SSS-38	115	11.8	5-15P
SG-SSS-48	115	12	5-15P
SG-SSS-57	115/230	8.9	L14-20P
SG-SSS-76	115/230	9.8	L14-20P

STANDARD OPTIONS:

- Textured black, white or brushed stainless steel interior finish
- Black or white laminate exterior finish
- Two 16" adjustable tempered glass shelves with integrated LED lighting in the service display
- LED lighting attached at the top of the display
- Thermal glass rear sliding doors on the service display
- Fixed tempered front glass with an opening for self-service display

CUSTOM OPTIONS:

EXTERIOR FINISHES	
Formica laminate finish: ____	
Other laminate finish (specify): ____	
Customer laminate choices	
Oak Veneer Plywood	
- Vertical grain direction	
- Horizontal grain direction	
Birch/Maple Veneer Plywood	
- Vertical grain direction	
- Horizontal grain direction	
Clear Finish applied to veneer	
Stain Finish Choice _____	
1" black McCue impact bumper strip applied to the front of the display	
Other McCue impact bumper strip colors Available upon request	

END PANELS	
Mirrored end panel glass	
Stainless Steel T-mold edging	
1" black McCue impact bumper strip applied to the outside of the end panel	
Other McCue impact bumper strip colors available upon request	

MISCELLANEOUS	
Heavy duty lockable casters	
Rear fold-down work shelf	
Mirrored rear sliding doors	
Wire security grill panel for service display area	
Price tag mold strip for tempered glass shelves	

ADDITIONAL FEATURES:

- Designed to maintain product temperature of 38-41°F with a maximum ambient atmosphere of 75°F/55% humidity
- Hot gas condensate evaporation system
- ETL Listed and Sanitation certified to NSF 7
- 1 Year Parts & Labour Warranty
- Rear air intake, front discharge. Avoid any obstructions in these areas

CURVED GLASS SERVICE DISPLAY

REFRIGERATED

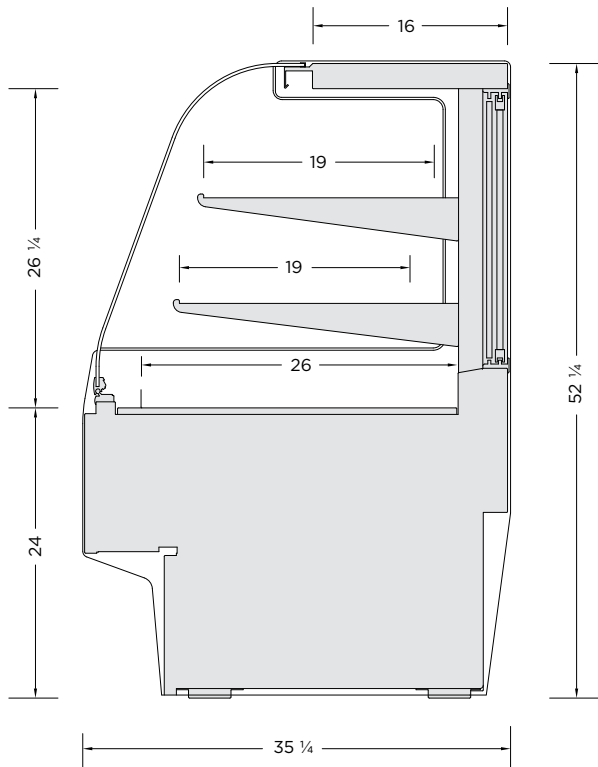





MODEL	LENGTH
RH3M-38	40 1/4"
RH3M-48	49 7/8"
RH3M-57	59 3/8"
RH3M-76	78 1/2"
RH3M-96	97 5/8"

FEATURES:

- 3 interior finishes, textured black, white or brushed stainless steel
- Many exterior colors, patterns and wood grain finishes available
- R-134A self-contained refrigeration
- 15" & 17" adjustable tempered glass shelves with integrated LED lighting
- Removable base deck panels for easy cleaning and service
- Tilt-out front glass for easy cleaning
- Air circulating defogging system to keep the front glass clear of condensation
- LED lighting attached to the top ledge of the display
- Thermal rear sliding doors
- Many custom options available. Refer to the options schedule on next page

SUGGESTED APPLICATIONS:

-  Bakery
-  Restaurants
-  Deli
-  Butcher shops
-  Cafe

Note: Information and specifications may change due to engineering improvements.



CURVED GLASS SERVICE DISPLAY

 REFRIGERATED

ELECTRICAL SPECIFICATIONS			
MODEL	VOLTS	AMPS	NEMA PLUG
RH3M-38	115	9.1	5-15P
RH3M-48	115	12.3	5-20P
RH3M-57	115	13	5-20P
RH3M-76	115/230	9.8	L14-20P
RH3M-96	115/230	10.3	L14-20P

STANDARD OPTIONS:

- Textured black, white or brushed stainless steel interior finish
- Black or white laminate exterior finish
- 15" & 17" adjustable tempered glass shelves with integrated LED lighting
- LED lighting attached at the top of the service display
- Thermal glass rear sliding doors
- Tilt-out curved front glass
- Air circulating defogging system to keep front glass clear of condensation

CUSTOM OPTIONS:

EXTERIOR FINISHES	
Formica laminate finish: ____	
Other laminate finish (specify): ____	
Customer laminate choices	
Oak Veneer Plywood	
- Vertical grain direction	
- Horizontal grain direction	
Birch/Maple Veneer Plywood	
- Vertical grain direction	
- Horizontal grain direction	
Clear Finish applied to veneer	
Stain Finish Choice _____	
1" black McCue impact bumper strip applied to the front of the display	
Other McCue impact bumper strip colors Available upon request	

END PANELS	
Solid	
- LH (visualized from the front)	
- RH (visualized from the front)	
Interior laminate the same as exterior	
Mirrored interior	
Brushed Stainless Steel interior	
Mirrored end panel glass	
Stainless Steel T-mold edging	
1" black McCue impact bumper strip applied to the outside of the end panel	
Other McCue impact bumper strip colors available upon request	

MISCELLANEOUS	
Heavy duty lockable casters	
Rear fold-down work shelf	
Add one shelf level (with LED light strip)	
Eliminate 1 shelf level	
Mirror rear sliding doors	
Locks for rear sliding doors	
Price tag mold strip for tempered glass shelves	

ADDITIONAL FEATURES:

- Designed to maintain product temperature of 38-41°F with a maximum ambient atmosphere of 75°F/55% humidity
- Hot gas condensate evaporation system
- ETL Listed and Sanitation certified to NSF 7
- 1 Year Parts & Labour Warranty
- Rear air intake, front discharge. Avoid any obstructions in these areas

CURVED GLASS DRY SERVICE DISPLAY

□ AMBIENT

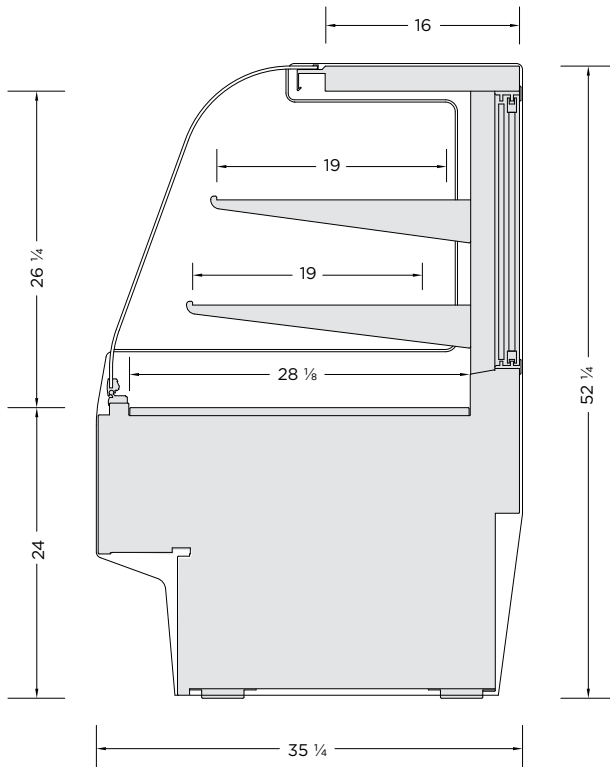





MODEL	LENGTH
DH3M-38	40 1/4"
DH3M-48	49 7/8"
DH3M-57	59 3/8"
DH3M-76	78 1/2"
DH3M-96	97 5/8"

FEATURES:

- 3 interior finishes, textured black, white or brushed stainless steel
- Many exterior colors, patterns and wood grain finishes available
- 15" & 17" adjustable tempered glass shelves with integrated LED lighting
- Tilt-out curved front glass for easy cleaning
- LED lighting attached to the top ledge of the display
- Rear sliding doors
- Many custom options available. Refer to the options schedule on next page

SUGGESTED APPLICATIONS:

-  Bakery
-  Restaurants
-  Deli
-  Butcher shops
-  Cafe

Note: Information and specifications may change due to engineering improvements.



CURVED GLASS DRY SERVICE DISPLAY

□ AMBIENT

ELECTRICAL SPECIFICATIONS			
MODEL	VOLTS	AMPS	NEMA PLUG
DH3M-38	115	.5	5-15P
DH3M-48	115	.5	5-15P
DH3M-57	115	1.0	5-15P
DH3M-76	115	1.0	5-15P
DH3M-96	115	1.0	5-15P

STANDARD OPTIONS:

- Textured black, white or brushed stainless steel interior finish
- Black or white laminate exterior finish
- 15" & 17" adjustable tempered glass shelves with integrated LED lighting
- LED lighting attached at the top of the service display
- Glass rear sliding doors
- Tilt-out curved front glass

CUSTOM OPTIONS:

EXTERIOR FINISHES	
Formica laminate finish: ____	
Other laminate finish (specify): ____	
Customer laminate choices	
Oak Veneer Plywood	
- Vertical grain direction	
- Horizontal grain direction	
Birch/Maple Veneer Plywood	
- Vertical grain direction	
- Horizontal grain direction	
Clear Finish applied to Veneer	
Stain Finish Choice _____	
1" black McCue impact bumper strip applied to the front of the display	
Other McCue impact bumper strip colors Available upon request	

END PANELS	
Solid	
- LH (visualized from the front)	
- RH (visualized from the front)	
Interior laminate the same as exterior	
Mirrored interior	
Brushed Stainless Steel interior	
Mirrored end panel glass	
Stainless Steel T-mold edging	
1" black McCue impact bumper strip applied to the outside of the end panel	
Other McCue impact bumper strip colors available upon request	

MISCELLANEOUS	
Heavy duty lockable casters	
Rear fold-down work shelf	
Add 1 shelf level (with LED light strip)	
Eliminate 1 shelf level	
Mirrored rear sliding doors	
Locks for rear sliding doors	
Price tag mold strip for tempered glass shelves	

ADDITIONAL FEATURES:

- ETL Listed and Sanitation certified to NSF 7
- 1 Year Parts & Labour Warranty

SQUARE GLASS SERVICE DISPLAY

REFRIGERATED

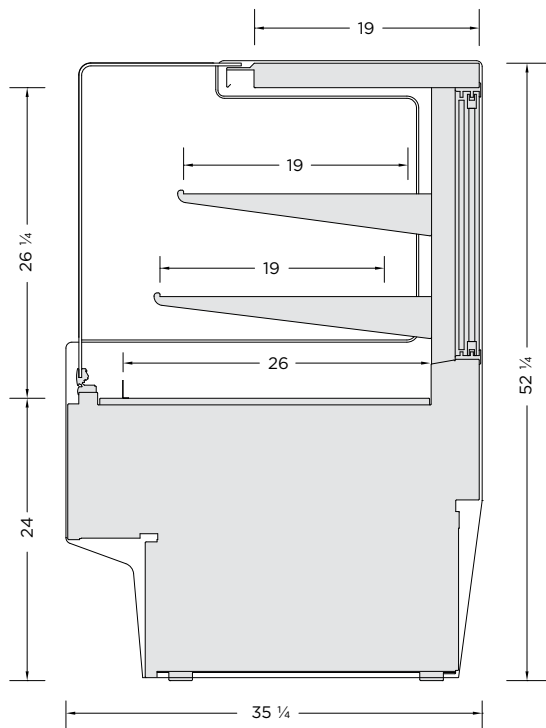





MODEL	LENGTH
SG-RH3-38	40 1/4"
SG-RH3-48	49 7/8"
SG-RH3-57	59 3/8"
SG-RH3-76	78 1/2"
SG-RH3-96	97 5/8"

FEATURES:

- 3 interior finishes, textured black, white or brushed stainless steel
- Many exterior colors, patterns and wood grain finishes available
- R-134A self-contained refrigeration
- Two 19" adjustable tempered glass shelves with integrated LED lighting
- Removable base deck panels for easy cleaning and service
- Air circulating defogging system to keep the front glass clear of condensation
- LED lighting attached to the top ledge of the display
- Thermal rear sliding doors
- Exclusive one piece 90° bent front glass for better visibility and glass alignment
- Tilt-out front glass for easy cleaning
- Many custom options available. Refer to the options schedule on next page

SUGGESTED APPLICATIONS:

-  Bakery
-  Restaurants
-  Deli
-  Butcher shops
-  Cafe

Note: Information and specifications may change due to engineering improvements.



SQUARE GLASS SERVICE DISPLAY

 REFRIGERATED

ELECTRICAL SPECIFICATIONS			
MODEL	VOLTS	AMPS	NEMA PLUG
SG-RH3-38	115	9.1	5-15P
SG-RH3-48	115	12.3	5-20P
SG-RH3-57	115	13	5-20P
SG-RH3-76	115/230	9.8	L14-20P
SG-RH3-96	115/230	10.3	L14-20P

STANDARD OPTIONS:

- Textured black, white or brushed stainless steel interior finish
- Black or white laminate exterior finish
- Two 19" adjustable tempered glass shelves with integrated LED lighting
- LED lighting attached at the top of the service display
- Thermal glass rear sliding doors
- Tilt-out one-piece 90° square front glass
- Air circulating defogging system to keep the front glass clear of condensation

CUSTOM OPTIONS:

EXTERIOR FINISHES	
Formica laminate finish: ____	
Other laminate finish (specify): ____	
Customer laminate choices	
Oak Veneer Plywood	
- Vertical grain direction	
- Horizontal grain direction	
Birch/Maple Veneer Plywood	
- Vertical grain direction	
- Horizontal grain direction	
Clear Finish applied to veneer	
Stain Finish Choice _____	
1" black McCue impact bumper strip applied to the front of the display	
Other McCue impact bumper strip colors Available upon request	

END PANELS	
Solid	
- LH (visualized from the front)	
- RH (visualized from the front)	
Interior laminate the same as exterior	
Mirrored interior	
Brushed Stainless Steel interior	
Mirrored end panel glass	
Stainless Steel T-mold edging	
1" black McCue impact bumper strip applied to the outside of the end panel	
Other McCue impact bumper strip colors available upon request	

MISCELLANEOUS	
Heavy duty lockable casters	
Rear fold-down work shelf	
Add 1 shelf level (with LED light strip)	
Eliminate 1 shelf level	
Mirrored rear sliding doors	
Locks for rear sliding doors	
Price tag mold strip for tempered glass shelves	

ADDITIONAL FEATURES:

- Designed to maintain product temperature of 38-41°F with a maximum ambient atmosphere of 75°F/55% humidity
- Hot gas condensate evaporation system
- ETL Listed and Sanitation certified to NSF 7
- 1 Year Parts & Labour Warranty
- Rear air intake, front discharge. Avoid any obstructions in these areas

SQUARE GLASS DRY SERVICE DISPLAY

□ AMBIENT

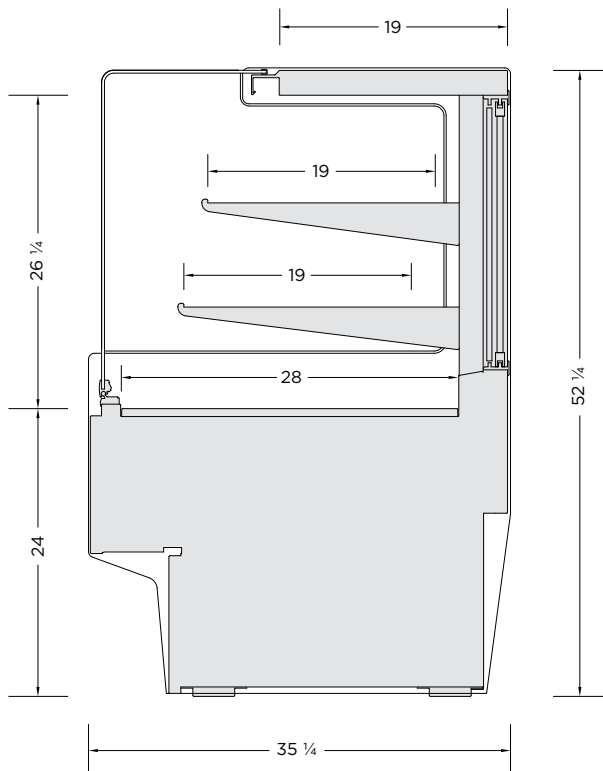





MODEL	LENGTH
SG-DH3-38	40 1/4"
SG-DH3-48	49 7/8"
SG-DH3-57	59 3/8"

FEATURES:

- 3 interior finishes, textured black, white or brushed stainless steel
- Many exterior colors, patterns and wood grain finishes available
- Two 19" adjustable tempered glass shelves with integrated LED lighting
- Tilt-out front glass for easy cleaning
- LED lighting attached to the top ledge of the display
- Rear sliding doors
- Exclusive one piece 90° bent front glass for better presentation and alignment
- Many custom options available. Refer to the options schedule on next page

SUGGESTED APPLICATIONS:

-  Bakery
-  Restaurants
-  Deli
-  Butcher shops
-  Cafe

Note: Information and specifications may change due to engineering improvements.



SQUARE GLASS DRY SERVICE DISPLAY

□ AMBIENT

ELECTRICAL SPECIFICATIONS			
MODEL	VOLTS	AMPS	NEMA PLUG
SG-DH3-38	115	.5	5-15P
SG-DH3-48	115	.5	5-15P
SG-DH3-57	115	1.0	5-15P

STANDARD OPTIONS:

- Textured black, white or brushed stainless steel interior finish
- Black or white laminate exterior finish
- Two 19" adjustable tempered glass shelves with integrated LED lighting
- LED lighting attached at the top of the service display
- Glass rear sliding doors
- Tilt-out one-piece 90° square front glass

CUSTOM OPTIONS:

EXTERIOR FINISHES	
Formica laminate finish: ____	
Other laminate finish (specify): ____	
Customer laminate choices	
Oak Veneer Plywood	
- Vertical grain direction	
- Horizontal grain direction	
Birch/Maple Veneer Plywood	
- Vertical grain direction	
- Horizontal grain direction	
Clear Finish applied to veneer	
Stain Finish Choice _____	
1" black McCue impact bumper strip applied to the front of the display	
Other McCue impact bumper strip colors Available upon request	

END PANELS	
Solid	
- LH (visualized from the front)	
- RH (visualized from the front)	
Interior laminate the same as exterior	
Mirrored interior	
Brushed Stainless Steel interior	
Mirrored end panel glass	
Stainless Steel T-mold edging	
1" black McCue impact bumper strip applied to the outside of the end panel	
Other McCue impact bumper strip colors available upon request	

MISCELLANEOUS	
Heavy duty lockable casters	
Rear fold-down work shelf	
Add 1 shelf level (with integrated LED light strip)	
Eliminate 1 shelf level	
Mirrored rear sliding doors	
Locks for rear sliding doors	
Price tag mold strip for tempered glass shelves	

ADDITIONAL FEATURES:

- ETL Listed and Sanitation certified to NSF 7
- 1 Year Parts & Labour Warranty

THREE-LEVEL UPRIGHT SELF-SERVICE DISPLAY - 53"H

 REFRIGERATED



Standard features shown



Custom options available, refer to options schedule on next page

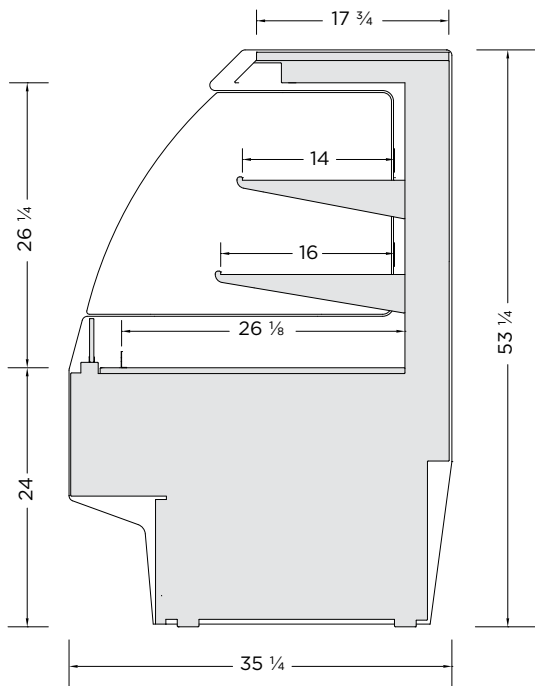







MODEL	LENGTH
MD3M-24-53	26"
MD3M-38-53	40 1/4"
MD3M-48-53	49 7/8"
MD3M-57-53	59 3/8"
MD3M-76-53	78 1/2"
MD3M-96-53	97 5/8"

FEATURES:

- Many exterior finish options available: powdercoat paint, brushed stainless steel, laminates and natural wood finishes
- 3 interior finish options: textured powdercoat black, white and brushed stainless steel
- Other custom options are offered. Refer to the options schedule on the next page
- A LED light strip is mounted on the top ledge of the display area.
- 1-14" and 1-16" adjustable metal shelves with integrated LED lighting.
- The LED lighting is available in various light intensities/spectrums
- Designed to maintain the critical temperature of the products within the display at a range of 38-41°F (3-5°C) with an ambient atmosphere of 75°F (24°C)/55% humidity
- ETL electrical certification and NSF 7 standards
- New R-513A (non ozone depleting, low global warming potential) refrigerant used in the self-contained refrigeration system
- The refrigeration system is designed to pull fresh air and heated exhaust air through a front vent integrated in the base of the display
- Remote refrigeration available. Contact Cayuga Displays for details

SUGGESTED APPLICATIONS:

-  Bakery
-  Restaurants
-  Deli
-  Butcher shops
-  Cafe
-  Produce

Note: Information and specifications may change due to engineering improvements.



THREE-LEVEL UPRIGHT SELF-SERVICE DISPLAY - 53”H

REFRIGERATED

ELECTRICAL SPECIFICATIONS			
MODEL	VOLTS	AMPS	NEMA PLUG
MD3M-24-53	115	11.7	5-15P
MD3M-38-53	115	11.7	5-15P
MD3M-48-53	115	11.7	5-15P
MD3M-57-53	115/230	8.7	L14-20P
MD3M-76-53	115/230	12.4	L14-20P
MD3M-96-53	115/230	12.4	L14-20P

STANDARD FEATURES:

- 3 interior finish options: textured powdercoat black, white and brushed stainless steel
- Black or white laminate exterior finish
- Solid End Panels with black or white interior finish
- A LED light strip is mounted on the top ledge of the display area
- 1-14” and 1-16” adjustable metal shelves with integrated LED lighting
- The refrigeration system is designed to pull fresh air and heated exhaust air through a front vent integrated in the base of the display

CUSTOM OPTIONS:

EXTERIOR FINISHES	
Formica laminate finish: ____	
Other laminate finish (specify): ____	
Customer laminate choices	
Brushed Stainless Steel	
Oak Veneer Plywood	
- Vertical grain direction	
- Horizontal grain direction	
Birch/Maple Veneer Plywood	
- Vertical grain direction	
- Horizontal grain direction	
Clear Finish applied to veneer	
Stain Finish Choice _____	
1” black McCue impact bumper strip applied to the front of the display	
Other McCue impact bumper strip colors Available upon request	

END PANELS	
Interior laminate the same as exterior	
Brushed stainless steel interior	
Mirrored interior	
Tempered glass end panels	
Mirrored glass end panels	
1” black McCue impact bumper strip applied to the end panel	
Other McCue impact bumper strip colors available upon request	

MISCELLANEOUS	
Additional shelf with integrated LED lighting	
Tempered glass shelves with integrated LED lighting	
Roll-down thermal night curtain	
Heavy duty lockable casters	

ADDITIONAL FEATURES:

- Designed to maintain the critical temperature of the products within the display at a range of 38-41°F (3-5°C) with an ambient atmosphere of 75° (24°C)/55% humidity. Designed for holding pre chilled product only
- Hot gas condensate evaporation system (most units)
- ETL listed and sanitation certified to NSF 7
- 1 year parts and labor warranty

THREE-LEVEL UPRIGHT SELF-SERVICE DISPLAY - 53”H

Standard features shown

MD3M-24-53



Finishes:
Powdercoat,
Textured Black

Custom option shown



Finishes:
Laminate,
Brazilwood (7946)

MD3M-38-53



Finishes:
Powdercoat,
Textured Black

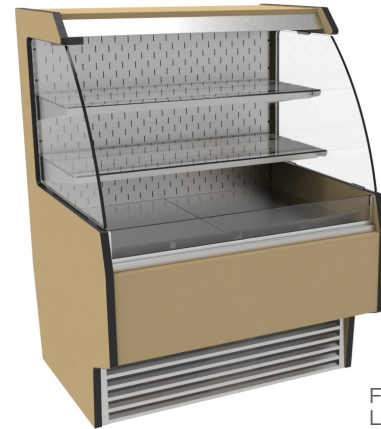

Finishes:
Laminate,
Soft Gold Mesh (4911)

MD3M-48-53



Finishes:
Powdercoat,
Textured Black



Finishes:
Laminate,
Windswept Bronze (4795)

THREE-LEVEL UPRIGHT SELF-SERVICE DISPLAY - 53”H

Standard features shown

MD3M-57-53



Finishes:
Powdercoat,
Textured Black

Custom option shown



Finishes:
Laminate,
Vapor Strandz (4939k)

MD3M-76-53



Finishes:
Powdercoat,
Textured Black



Finishes:
Laminate,
Sprout (4918)

MD3M-96-53

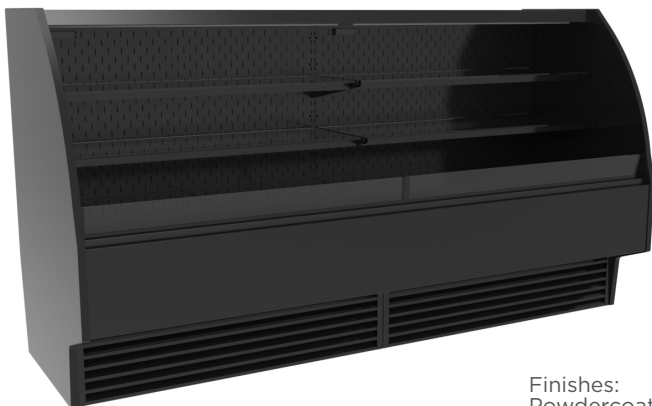

Finishes:
Powdercoat,
Textured Black



Finishes:
Laminate,
Old Mill Oak (7973k)

FOUR-LEVEL UPRIGHT SELF-SERVICE DISPLAY - 63"H

 REFRIGERATED



Standard features shown



Custom options available, refer to options schedule on next page

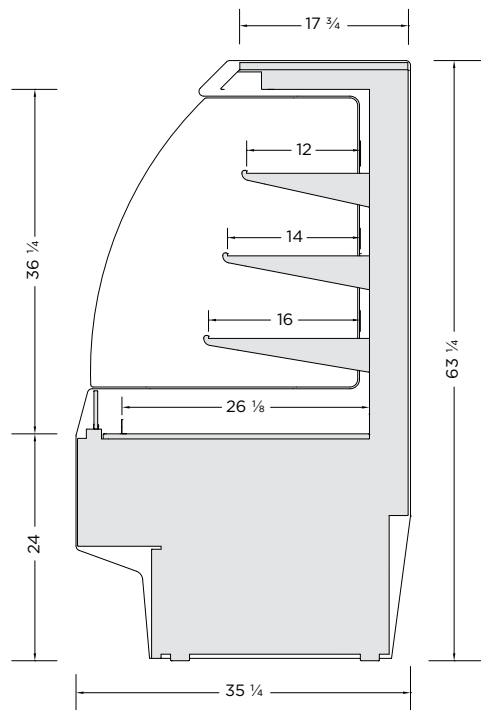







MODEL	LENGTH
MD4M-24-63	26"
MD4M-38-63	40 1/4"
MD4M-48-63	49 7/8"
MD4M-57-63	59 3/8"
MD4M-76-63	78 1/2"
MD4M-96-63	97 5/8"

FEATURES:

- Many exterior finish options available: powdercoat paint, brushed stainless steel, laminates and natural wood finishes
- 3 interior finish options: textured powdercoat black, white and brushed stainless steel
- Other custom options are offered. Refer to the options schedule on the next page
- A LED light strip is mounted on the top ledge of the display area.
- 1-12", 1-14" and 1-16" adjustable metal shelves with integrated LED lighting.
- The LED lighting is available in various light intensities/spectrums
- Designed to maintain the critical temperature of the products within the display at a range of 38-41°F (3-5°C) with an ambient atmosphere of 75°F (24°C)/55% humidity
- ETL electrical certification and NSF 7 standards
- New R-513A (non ozone depleting, low global warming potential) refrigerant used in the self-contained refrigeration system
- The refrigeration system is designed to pull fresh air and heated exhaust air through a front vent integrated in the base of the display
- Remote refrigeration available. Contact Cayuga Displays for details

SUGGESTED APPLICATIONS:

-  Bakery
-  Restaurants
-  Deli
-  Butcher shops
-  Cafe
-  Produce

Note: Information and specifications may change due to engineering improvements.



FOUR-LEVEL UPRIGHT SELF-SERVICE DISPLAY - 63”H

 REFRIGERATED

ELECTRICAL SPECIFICATIONS			
MODEL	VOLTS	AMPS	NEMA PLUG
MD4M-24-63	115	11.7	5-15P
MD4M-38-63	115	11.7	5-15P
MD4M-48-63	115	11.7	5-15P
MD4M-57-63	115/230	8.7	L14-20P
MD4M-76-63	115/230	12.4	L14-20P
MD4M-96-63	115/230	12.4	L14-20P

STANDARD FEATURES:

- 3 interior finish options: textured powdercoat black, white and brushed stainless steel
- Black or white laminate exterior finish
- Solid End Panels with black or white interior finish
- A LED light strip is mounted on the top ledge of the display area
- 1-12”, 1-14” and 1-16” adjustable metal shelves with integrated LED lighting
- The refrigeration system is designed to pull fresh air and heated exhaust air through a front vent integrated in the base of the display

CUSTOM OPTIONS:

EXTERIOR FINISHES	
Formica laminate finish: ____	
Other laminate finish (specify): ____	
Customer laminate choices	
Brushed Stainless Steel	
Oak Veneer Plywood	
- Vertical grain direction	
- Horizontal grain direction	
Birch/Maple Veneer Plywood	
- Vertical grain direction	
- Horizontal grain direction	
Clear Finish applied to veneer	
Stain Finish Choice _____	
1” black McCue impact bumper strip applied to the front of the display	
Other McCue impact bumper strip colors Available upon request	

END PANELS	
Interior laminate the same as exterior	
Brushed stainless steel interior	
Mirrored interior	
Tempered glass end panels	
Mirrored glass end panels	
1” black McCue impact bumper strip applied to the end panel	
Other McCue impact bumper strip colors available upon request	

MISCELLANEOUS	
Additional shelf with integrated LED lighting	
Tempered glass shelves with integrated LED lighting	
Roll-down thermal night curtain	
Heavy duty lockable casters	

ADDITIONAL FEATURES:

- Designed to maintain the critical temperature of the products within the display at a range of 38-41°F (3-5°C) with an ambient atmosphere of 75° (24°C)/55% humidity. Designed for holding pre chilled product only
- Hot gas condensate evaporation system (most units)
- ETL listed and sanitation certified to NSF 7
- 1 year parts and labor warranty

FOUR-LEVEL UPRIGHT SELF-SERVICE DISPLAY - 63"H

Standard features shown

MD4M-24-63



Finishes:
Powdercoat,
Textured Black

Custom option shown



Finishes:
Laminate,
Brazilwood (7946)

MD4M-38-63



Finishes:
Powdercoat,
Textured Black

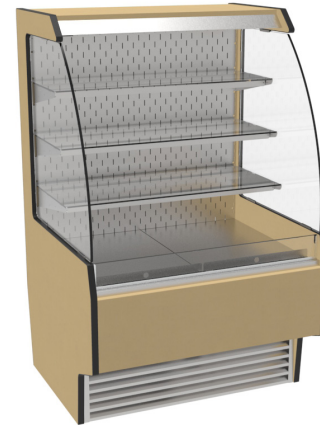

Finishes:
Laminate,
Soft Gold Mesh (4911)

MD4M-48-63



Finishes:
Powdercoat,
Textured Black



Finishes:
Laminate,
Windswept Bronze (4795)

FOUR-LEVEL UPRIGHT SELF-SERVICE DISPLAY - 63"H

Standard features shown

MD4M-57-63



Finishes:
Powdercoat,
Textured Black

Custom option shown



Finishes:
Laminate,
Vapor Strandz (4939k)

MD4M-76-63



Finishes:
Powdercoat,
Textured Black

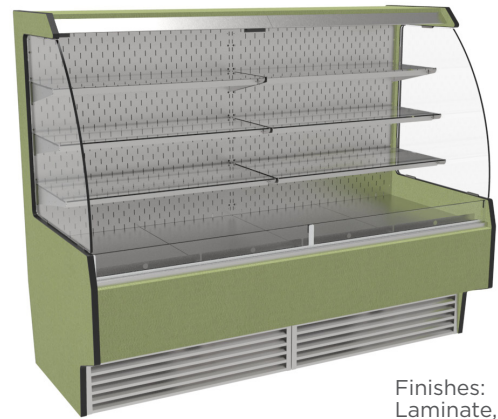

Finishes:
Laminate,
Sprout (4918)

MD4M-96-63

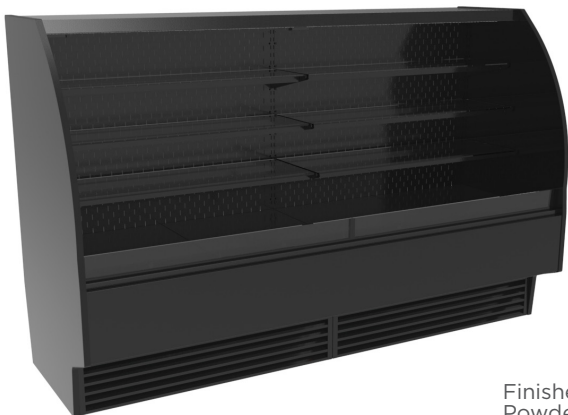

Finishes:
Powdercoat,
Textured Black



Finishes:
Laminate,
Old Mill Oak (7973k)

UPRIGHT THREE-LEVEL SELF-SERVICE DISPLAY

 REFRIGERATED









MODEL	LENGTH
GP3-38-54	40 1/4"
GP3-48-54	49 7/8"
GP3-57-54	59 3/8"

FEATURES:

- 3 interior finishes, textured black, white or brushed stainless steel
- Many exterior colors, patterns and wood grain finishes available
- R-134A self-contained refrigeration
- LED lighting attached to the top ledge of the display
- 10" & 14" adjustable metal shelves with integrated LED lighting and raised front lip to attach price tag mold
- Removable base deck panels for easy cleaning and service
- Many options available. Refer to the options schedule on next page

SUGGESTED APPLICATIONS:

- | | |
|--|---|
|  Bakery |  Restaurants |
|  Deli |  Butcher shops |
|  Cafe |  Produce |

Note: Information and specifications may change due to engineering improvements.

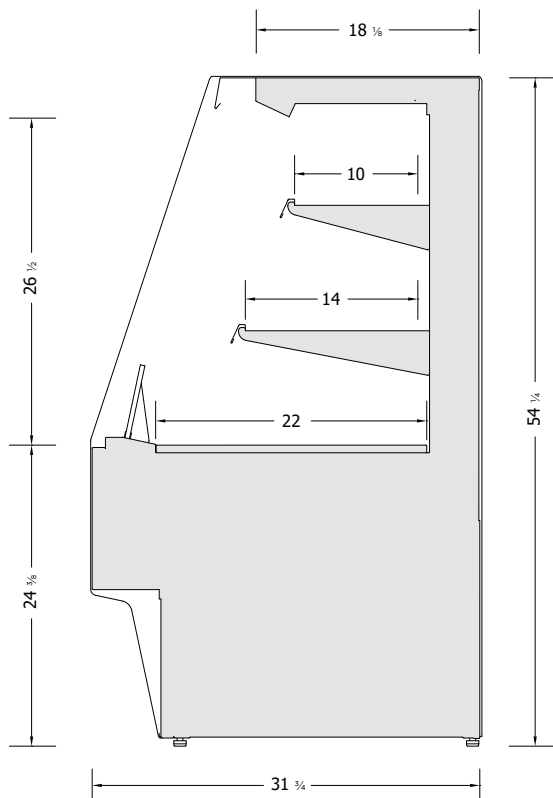



UPRIGHT THREE-LEVEL SELF-SERVICE DISPLAY

 REFRIGERATED

ELECTRICAL SPECIFICATIONS			
MODEL	VOLTS	AMPS	NEMA PLUG
GP3-38-54	115	12.3	5-20P
GP3-48-54	115/230	8.7	L14-20P
GP3-57-54	115/230	8.9	L14-20P

STANDARD OPTIONS:

- Textured black, white or brushed stainless steel interior finish
- Black or white laminate exterior finish
- 10" & 14" adjustable metal shelves with integrated LED lighting and raised front
- LED lighting attached at the top of the service display

CUSTOM OPTIONS:

EXTERIOR FINISHES	
Formica laminate finish: ____	
Other laminate finish (specify): ____	
Customer laminate choices	
Brushed Stainless Steel	
Oak Veneer Plywood	
- Vertical grain direction	
- Horizontal grain direction	
Birch/Maple Veneer Plywood	
- Vertical grain direction	
- Horizontal grain direction	
Clear Finish applied to veneer	
Stain Finish Choice _____	
1" black McCue impact bumper strip applied to the front of the display	
Other McCue impact bumper strip colors Available upon request	

END PANELS	
Interior laminate the same as exterior	
Brushed Stainless Steel interior	
Mirrored interior	
Stainless Steel T-mold edging	
1" black McCue impact bumper strip applied to the outside of the end panel	
Other McCue impact bumper strip colors available upon request	

MISCELLANEOUS	
Heavy duty lockable casters	
Price tag mold strip for shelves	
Add 1 shelf level (with integrated LED light strip)	
Eliminate 1 shelf level	
Rear venting kit for wall installation	

ADDITIONAL FEATURES:

- Designed to maintain product temperature of 38-41°F with a maximum ambient atmosphere of 75°F/55% Humidity
- Hot gas condensate evaporation system
- ETL Listed and Sanitation certified to NSF 7
- 1 Year Parts & Labour Warranty
- Front air intake, rear discharge. Avoid any obstructions in these areas. Allow 4" minimum clearance.

UPRIGHT FOUR-LEVEL SELF-SERVICE DISPLAY

 REFRIGERATED

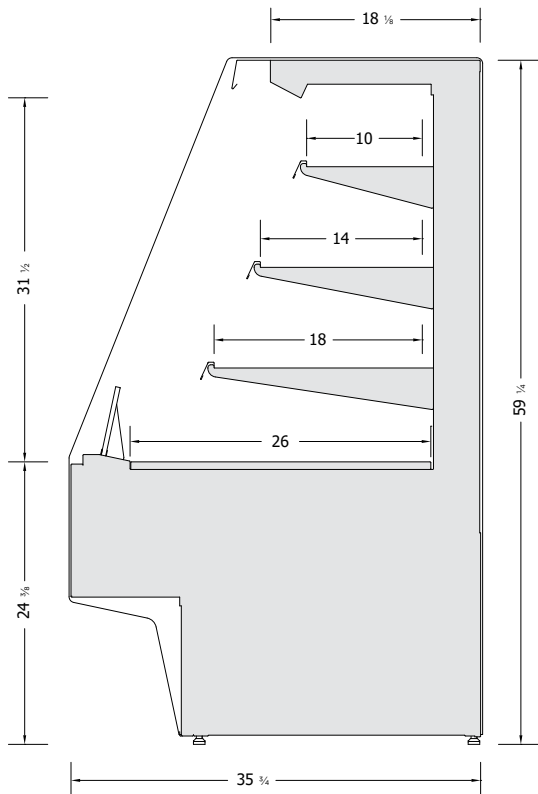







MODEL	LENGTH
GP4-38-60	40 1/4"
GP4-48-60	49 7/8"
GP4-57-60	59 3/8"

FEATURES:

- 3 interior finishes, textured black, white or brushed stainless steel
- Many exterior colors, patterns and wood grain finishes available
- R-134A self-contained refrigeration
- LED lighting attached to the top ledge of the display
- 10", 14" & 18" adjustable metal shelves with integrated LED lighting and raised front lip to attach price tag mould
- Removable base deck panels for easy cleaning and service
- Many options available. Refer to the options schedule on next page

SUGGESTED APPLICATIONS:

-  Bakery
-  Restaurants
-  Deli
-  Butcher shops
-  Cafe
-  Produce

Note: Information and specifications may change due to engineering improvements.



UPRIGHT FOUR-LEVEL SELF-SERVICE DISPLAY

 REFRIGERATED

ELECTRICAL SPECIFICATIONS			
MODEL	VOLTS	AMPS	NEMA PLUG
GP4-38-60	115	12.3	5-20P
GP4-48-60	115/230	8.7	L14-20P
GP4-57-60	115/230	8.9	L14-20P

STANDARD OPTIONS:

- Textured black, white or brushed stainless steel interior finish
- Black or white laminate exterior finish
- 10", 14" & 18" adjustable metal shelves with integrated LED lighting and raised front
- LED lighting attached at the top of the service display

CUSTOM OPTIONS:

EXTERIOR FINISHES	
Formica laminate finish: ____	
Other laminate finish (specify): ____	
Customer laminate choices	
Brushed Stainless Steel	
Oak Veneer Plywood	
- Vertical grain direction	
- Horizontal grain direction	
Birch/Maple Veneer Plywood	
- Vertical grain direction	
- Horizontal grain direction	
Clear Finish applied to veneer	
Stain Finish Choice _____	
1" black McCue impact bumper strip applied to the front of the display	
Other McCue impact bumper strip colors Available upon request	

END PANELS	
Interior laminate the same as exterior	
Brushed Stainless Steel interior	
Mirrored interior	
Stainless Steel T-mold edging	
1" black McCue impact bumper strip applied to the outside of the end panel	
Other McCue impact bumper strip colors available upon request	

MISCELLANEOUS	
Heavy duty lockable casters	
Price tag mold strip for shelves	
Add 1 shelf level (with integrated LED light strip)	
Eliminate 1 shelf level	
Rear venting kit for wall installation	

ADDITIONAL FEATURES:

- Designed to maintain product temperature of 38-41°F with a maximum ambient atmosphere of 75°F/55% Humidity
- Hot gas condensate evaporation system
- ETL Listed and Sanitation certified to NSF 7
- 1 Year Parts & Labour Warranty
- Front air intake, rear discharge. Avoid any obstructions in these areas. Allow 4" minimum clearance.

UPRIGHT THREE-LEVEL SLIM-LINE SELF-SERVICE DISPLAY

 REFRIGERATED

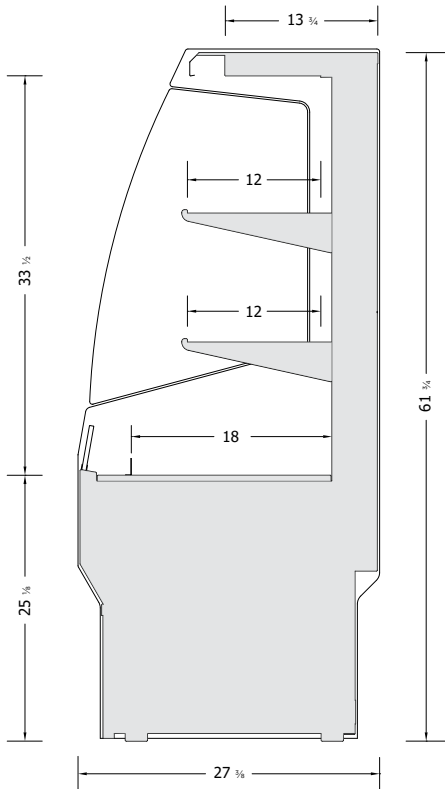







MODEL	LENGTH
SL-RSS-38-60	40 1/4"
SL-RSS-48-60	49 7/8"
SL-RSS-57-60	59 3/8"

FEATURES:

- 3 interior finishes, textured black, white or brushed stainless steel
- Many exterior colors, patterns and wood grain finishes available
- R-134A self-contained refrigeration
- LED lighting attached to the top ledge of the display
- Two adjustable metal shelves with integrated LED lighting and raised front lip to attach price tag mould
- Removable base deck panels for easy cleaning and service
- Many options available. Refer to the options schedule on next page

SUGGESTED APPLICATIONS:

-  Bakery
-  Restaurants
-  Deli
-  Butcher shops
-  Cafe
-  Produce

Note: Information and specifications may change due to engineering improvements.



UPRIGHT THREE-LEVEL SLIM-LINE SELF-SERVICE DISPLAY

 REFRIGERATED

ELECTRICAL SPECIFICATIONS			
MODEL	VOLTS	AMPS	NEMA PLUG
SL-RSS-38-60	115	12.3	5-20P
SL-RSS-48-60	115/230	8.7	L14-20P
SL-RSS-57-60	115/230	8.9	L14-20P

STANDARD OPTIONS:

- Textured black, white or brushed stainless steel interior finish
- Black or white laminate exterior finish
- Two 12" adjustable metal shelves with integrated LED lighting and raised front lip to attach price tag molding
- LED lighting attached at the top of the service display

CUSTOM OPTIONS:

EXTERIOR FINISHES	
Formica laminate finish: ____	
Other laminate finish (specify): ____	
Customer laminate choices	
Brushed Stainless Steel	
Oak Veneer Plywood	
- Vertical grain direction	
- Horizontal grain direction	
Birch/Maple Veneer Plywood	
- Vertical grain direction	
- Horizontal grain direction	
Clear Finish applied to veneer	
Stain Finish Choice _____	
1" black McCue impact bumper strip applied to the front of the display	
Other McCue impact bumper strip colors Available upon request	

END PANELS	
Solid	
- LH (visualized from the front)	
- RH (visualized from the front)	
Interior laminate the same as exterior	
Brushed Stainless Steel interior	
Mirrored interior	
Mirrored end panel glass	
Stainless Steel T-mold edging	
1" black McCue impact bumper strip applied to the outside of the end panel	
Other McCue impact bumper strip colors available upon request	

MISCELLANEOUS	
Heavy duty lockable casters	
Price tag mold strip for shelves	
Add 1 shelf level (with integrated LED light strip)	
Eliminate 1 shelf level	
Rear venting kit for wall installation	

ADDITIONAL FEATURES:

- Designed to maintain product temperature of 38-41°F with a maximum ambient atmosphere of 75°F/55% Humidity
- Hot gas condensate evaporation system
- ETL Listed and Sanitation certified to NSF 7
- 1 Year Parts & Labour Warranty
- Front air intake, rear discharge. Avoid any obstructions in these areas. Allow 4" minimum clearance.

UPRIGHT FIVE-LEVEL SELF-SERVICE DISPLAY

REFRIGERATED

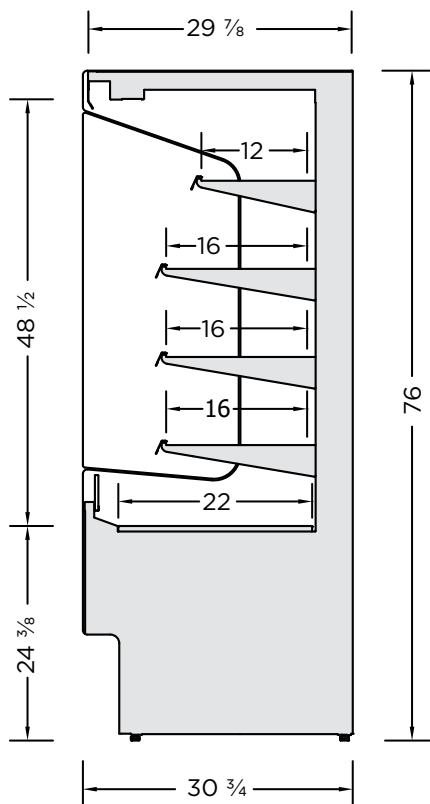

MODEL	LENGTH
RSS-38-76	40 1/4"
RSS-48-76	49 7/8"
RSS-57-76	59 3/8"

FEATURES:

- 3 interior finishes, textured black, white or brushed stainless steel
- Many exterior colors, patterns and wood grain finishes available
- R-134A self-contained refrigeration
- LED lighting attached to the top ledge of the display
- 12" & three 16" adjustable metal shelves with integrated LED lighting and raised front lip to attach price tag mould
- Removable base deck panels for easy cleaning and service
- Many options available. Refer to the options schedule on next page

SUGGESTED APPLICATIONS:

- Bakery
- Restaurants
- Deli
- Butcher shops
- Cafe
- Produce

Note: Information and specifications may change due to engineering improvements.



UPRIGHT FIVE-LEVEL SELF-SERVICE DISPLAY

 REFRIGERATED

ELECTRICAL SPECIFICATIONS			
MODEL	VOLTS	AMPS	NEMA PLUG
RSS-38-76	115/230	8.5	L14-20P
RSS-48-76	115/230	8.7	L14-20P
RSS-57-76	115/230	8.9	L14-20P

STANDARD OPTIONS:

- Textured black, white or brushed stainless steel interior finish
- Black or white laminate exterior finish
- 12" & three 16" tempered metal shelves with integrated LED lighting and raised front lip to attach price tag molding
- LED lighting attached at the top of the service display

CUSTOM OPTIONS:

EXTERIOR FINISHES	
Formica laminate finish: ____	
Other laminate finish (specify): ____	
Customer laminate choices	
Brushed Stainless Steel	
Oak Veneer Plywood	
- Vertical grain direction	
- Horizontal grain direction	
Birch/Maple Veneer Plywood	
- Vertical grain direction	
- Horizontal grain direction	
Clear Finish applied to veneer	
Stain Finish Choice _____	
1" black McCue impact bumper strip applied to the front of the display	
Other McCue impact bumper strip colors Available upon request	

END PANELS	
Solid	
- LH (visualized from the front)	
- RH (visualized from the front)	
Interior laminate the same as exterior	
Brushed Stainless Steel interior	
Mirrored interior	
Mirrored end panel glass	
Stainless Steel T-mold edging	
1" black McCue impact bumper strip applied to the outside of the end panel	
Other McCue impact bumper strip colors available upon request	

MISCELLANEOUS	
Price tag mold strip for shelves	
Add 1 shelf level (with integrated LED light strip)	
Eliminate 1 shelf level	
Tempered glass shelves instead of the standard metal shelves	
Top vent trim kit	
Roll-down security panel	

ADDITIONAL FEATURES:

- Designed to maintain product temperature of 38-41°F with a maximum ambient atmosphere of 75°F/55% Humidity
- Hot gas condensate evaporation system
- ETL Listed and Sanitation certified to NSF 7
- 1 Year Parts & Labour Warranty
- Front air intake, rear discharge. Avoid any obstructions in these areas. A rear venting kit (for narrower width units) is available to install the display against a wall or where the back is obstructed



Formica® Laminate

Formica Group provides surfaces that fuse beautiful design with purposeful functionality. Formica® Products provide versatile surfacing solutions that are inspired by and adapt to the way people live, work and play.

Formica® Brand Laminate offers a broader range of looks than ever before. Transform spaces with our modern laminates that are as beautiful as they are durable. Mix and match solids, patterns and finishes.

Product Features:

- Postforming
- Durable and Wear-resistant
- Horizontal and Vertical
- Impact Resistant

Formica® EliteForm

Our innovative Formica® EliteForm surfacing technology redefines the performance attributes of high pressure laminate to deliver a more durable laminate for today’s market. Formica® Laminate with EliteForm features superior scratch resistance over other laminate brands, the ability to postform to a smaller radius with better blister resistance, and more durable, long-lasting surfaces, including the Gloss texture in horizontal applications. EliteForm comes standard on all Formica® Laminates, at no additional cost.

Price Group One: All Colours are matte (-58) finish

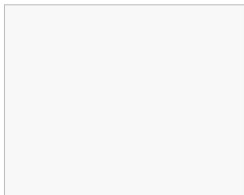

949
White

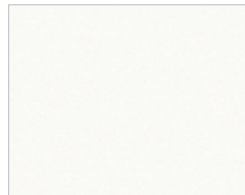

7197
Dover White

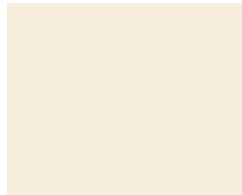

920
Almond

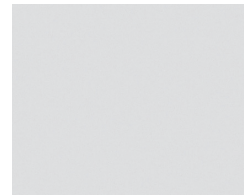

927
Folkstone



961
Fog



845
Spectrum Red



7897
Spectrum Green



914
Marine Blue



2297
Terril

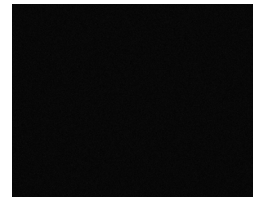

909
Black



6696
Carrara Bianco

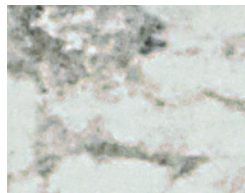

9476
White Ice Granite

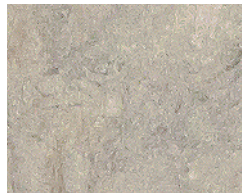

9497
Silver Quartzite



7732
Butterum Granite

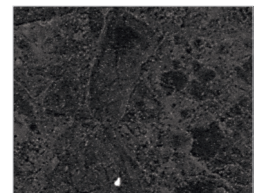

9527
Black Shalestone

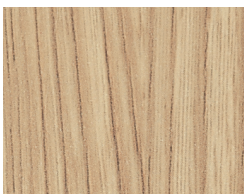

8844
Aged Ash



5883
Pecan Woodline



5884
Chestnut Woodline



9283
Walnut Riftwood



6414
Black Riftwood

Price Group Two: All Colours are matte finish



6997
Pale Brushstroke



6998
Wood Brushstroke

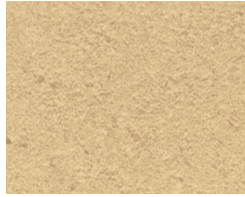

7813
Cardboard Solidz



9319
Stainless



8918
Blackened Steel



9310
White Marble Herringbone



9285
White Twill



6698
Paloma Pear



503
Stone Grafix



8830
Elemental Concrete



8841
White Ash



5785
Ashwood Beige



5795
Camel Elm



8845
Bleached Legno



8916
Blackened Fiberwood



86992
Hardrock Maple



7012
Amber Maple



8677
Scandi Rift Oak



6995
Cherry Walnut



7759
Select Cherry



Formica Canada Inc. is located in St-jean-sur-Richelieu, Quebec, and employs more than 250 people.

Formica Canada is proud to be part of the Well Made Here local purchasing program.

As the inventor of high pressure laminate, Formica Corporation has always worked to provide innovative, high quality products. Efficient use of resources is at our core, and we have taken many steps to improve our environmental footprint - from reusing the water in our presses to incorporating recycled materials into our surfacing products. We are committed to a long-term planning horizon that includes becoming an industry-leading environmental steward.



For larger laminate sample, please visit:
cayugadisplays.com 1-800-839-5536
formica.com 1-800-FORMICA™

HOW TO ORDER

We'll help you select the right case for your requirements. The steps below will help us to serve you best.

- 1 Choose the showcase that meets your displays requirements from the product specification sheets.
- 2 Review the options table found on the specification sheet and make your selections of the options provided.
- 3 Select from the large pallet of colours found on the last five pages of the brochure, or choose a stainless steel, standard black or white for the exterior finish of your showcase.
- 4 E-mail your request for a quote to your Cayuga sales representative or sales@cayugadisplays.com and we will quickly respond to your request. Please include your full contact information in case we have any questions.

Contact the inside sales team

Cayuga Displays

E: sales@cayugadisplays.com

T: 1-800-839-5536

F: 1-905-772-3179



T: 800.839.5536 F: 905.772.3179

E: sales@cayugadisplays.com

**A: 88 Talbot St E, PO Box 130
Cayuga, ON N0A 1E0**

